

Worm Gear Reducers

15mm Input Shaft Double Sided • 25mm Output Bore
72.5mm Centre Distance • T_{2max} 90Nm – 164Nm • **10:1 - 120:1**

Worm Gear Rotation Direction.

RH-Right Hand

When input rotation is clockwise, output gear is pulled towards input.

When input is counter-clockwise, output gear is pushed away from input.

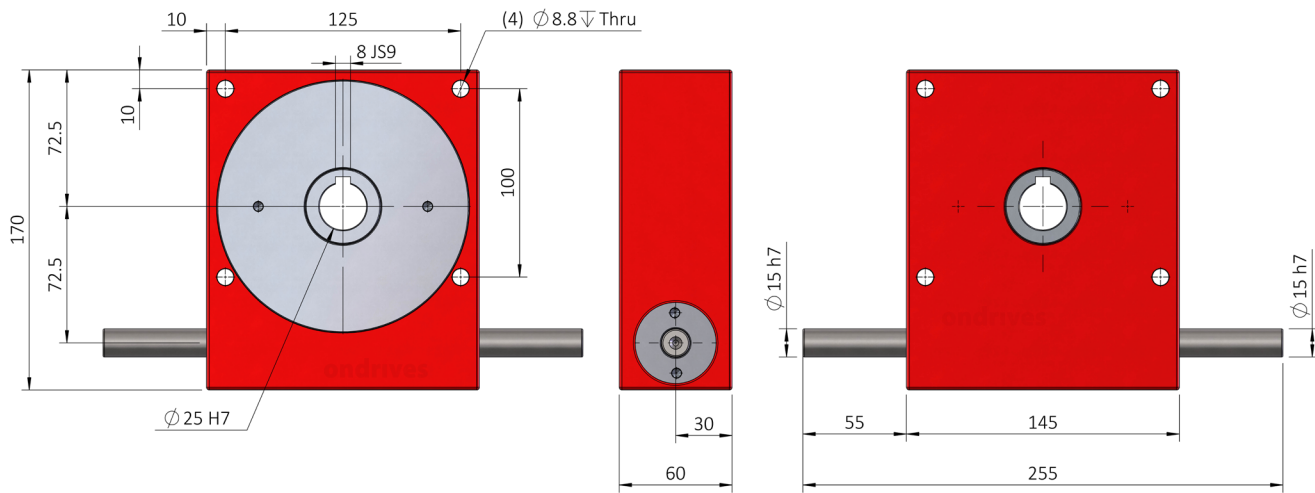
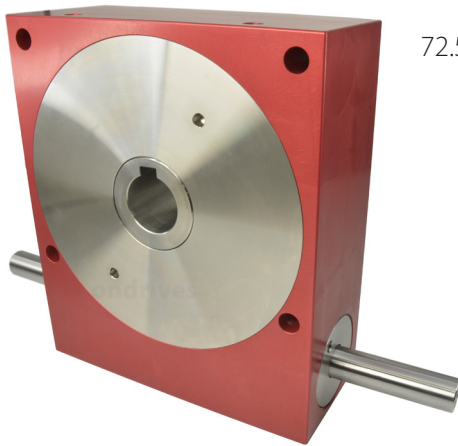

	Part Numbers					
Output Backlash j	Output Backlash j A	Output Backlash j AR	Gear Ratio i	Efficiency ηz	Lead Direction	Reflected Inertia at Input $kg \cdot m^2$
$\leq 0.50^\circ$	$\leq 0.13^\circ$	$\leq 0.066^\circ$		n1nom		
P70-10	P70-10A	P70-10AR	10:1	90%	Right Hand	6.04×10^{-5}
P70-12	P70-12A	P70-12AR	12:1	89%	Right Hand	5.03×10^{-5}
P70-15	P70-15A	P70-15AR	15:1	86%	Right Hand	4.21×10^{-5}
P70-20	P70-20A	P70-20AR	20:1	85%	Right Hand	3.57×10^{-5}
P70-30	P70-30A	P70-30AR	30:1	78%	Right Hand	3.11×10^{-5}
P70-60	P70-60A	P70-60AR	60:1	67%	Right Hand	2.84×10^{-5}
P70-120	P70-120A	P70-120AR	120:1	50%	Right Hand	2.48×10^{-5}

Weight: 6.4 kg.

Nom. Input Speed [S1 T₂n] n1nom: 1,000 min⁻¹ (r/min)

Max. Input Speed n1max: 3,000 min⁻¹ (r/min)

Lubrication: Grease Shell Gadus S5 V4P 2.5

Lubrication Temperature: Max. Operating $\approx 60^\circ C$

Max. Input Radial Load F_{r1}: 200N.

Max. Output Radial Load F_{r2}: 800N.

Max. Output Axial Load F_{a2}: 600N.

Testing in your application is necessary.

You will need to assess duty cycles and confirm suitability with your own calculations.

Figures listed are for guidance only.

Cooling may be needed dependent on application.

Worm Gear Reducers

15mm Input Shaft Double Sided • 25mm Output Bore
72.5mm Centre Distance • T_{2max} 90Nm – 164Nm • **10:1 - 120:1**

P Series Wormwheel Gearboxes

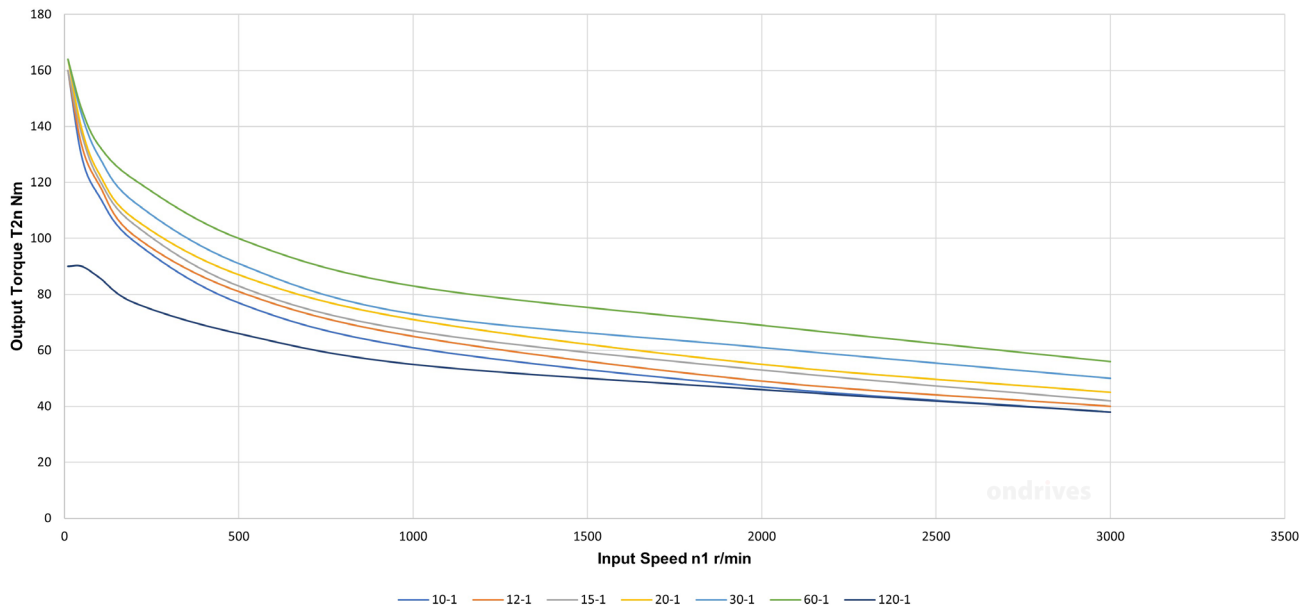

Worm Gear Reducers